

**iwata**

by ANEST IWATA

**maxxJet**

**IS1000**

**OPERATING INSTRUCTION MANUAL**



# NEED ASSISTANCE ?

**If you have any issues or warranty service questions, contact your local ANEST IWATA affiliate before returning to your place of purchase.**

**ANEST IWATA-MEDEA, INC.**

Portland, Oregon U.S.A.  
+1-503-253-7308 (M-F)  
info@iwata-medea.com  
www.iwata-airbrush.com

**ANEST IWATA SOUTH-EAST ASIA CO., LTD.**

Bangkok, Thailand  
+66-(0)-2643-2870  
www.anest-iwatasoutheastasia.com

**ANEST IWATA SOUTH AFRICA (PTY) LTD.**

Johannesburg, Republic of South Africa  
+27-11-463-2169/2265/2223  
www.anest-iwata.co.za

**ANEST IWATA CORPORATION**

Yokohama, Japan  
+81-(0)45-591-1111  
www.anest-iwata.co.jp

**ANEST IWATA STRATEGIC CENTER**

Cardano al Campo, Italy  
+39-0331-733120  
www.anest-iwataeu.com

**ANEST IWATA SHANGHAI**

Shanghai, China  
+86-(0)21-6407-9713 / 15 / 16  
www.anest-iwata-sh.com

**ANEST IWATA RUS LLC**

Moscow, Russia  
+7-495-938-77-28  
www.anestiwata.ru

**ANEST IWATA AUSTRALIA PTY LTD.**

Mt. Druitt, NSW  
+61-(02)-9853-2000  
www.anest-iwata.com.au

**ANEST IWATA (U.K.) LTD.**

Neots Cambs, England  
+44-(0)1480-405419  
www.anest-iwata.co.uk

**ANEST IWATA MOTHERSON LTD.**

Uttar Pradesh, India  
+91-(0)120-4600500 / 14 / 17  
www.anest-iwata.co.jp

**CENTURY TRADING CO., LTD.**

Seoul, Korea  
82-2-2163-0300  
www.centrating.co.kr

## FEATURES

- A powerful 1/6 hp, oil-less, two pole motor
- Runs at twice the RPMs of the Iwata Power Jet
- The Maxx Jet can power the Iwata G-Series airbrush-guns and light use with the RG-3
- Dual manifold air regulator with airbrush and spray gun holders
- 2.5 liter air storage tank and internal cooling fan
- Two braided air hoses for an airbrush and a spray gun
- Gear storage galore
- Strong, protective travel case with wheels and retractable handle
- Detachable top with handle opens a tray for your accessories
- External air intake filter
- On/Off switch and detachable power cord (10ft)
- Tank pressure gauge and internal cooling fan

### Voltage

If you bought the compressor in the country you're going to use it, it's completely ready to go. If you're going to transfer the compressor to another country with a different voltage, you'll need a plug adapter and the appropriate power converter. **WARNING: Using a plug adapter and power converter may cause unit to overheat. Any issues resulting from the use of a power adapter and/or power converter are not covered under the Anest Iwata-Medea warranty.**

# EXPLODED DIAGRAM

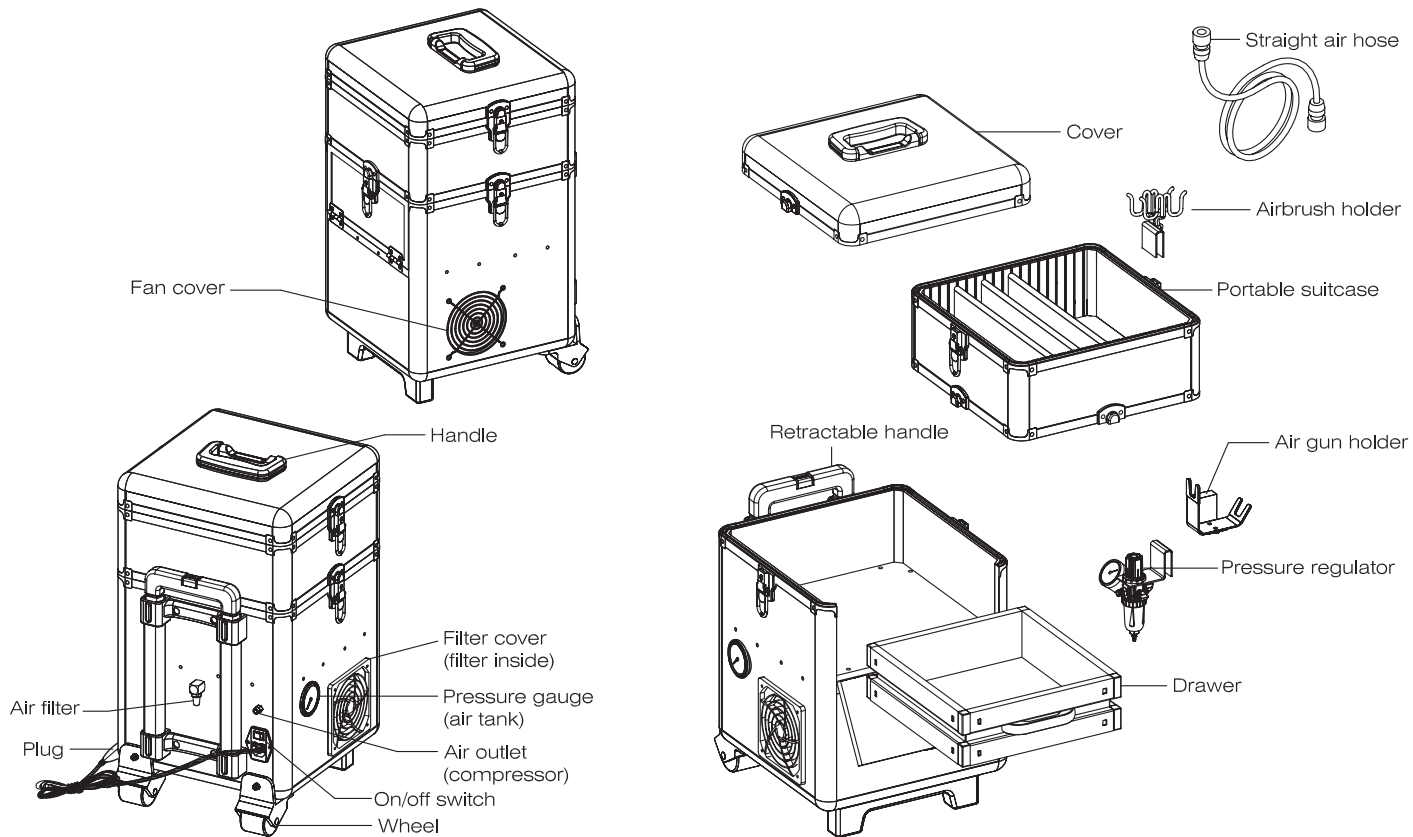

# EXPLODED DIAGRAM (CONT'D)

## Regulator/Moisture trap

Item # 3-DN23-001-A

### Regulator knob



**REMARK:**  
Pull up the Regulator Knob until you hear the "click" sound. Turn the cap right or left to adjust pressure. After finding the desired pressure, push the Regulator Knob down to lock the setting.

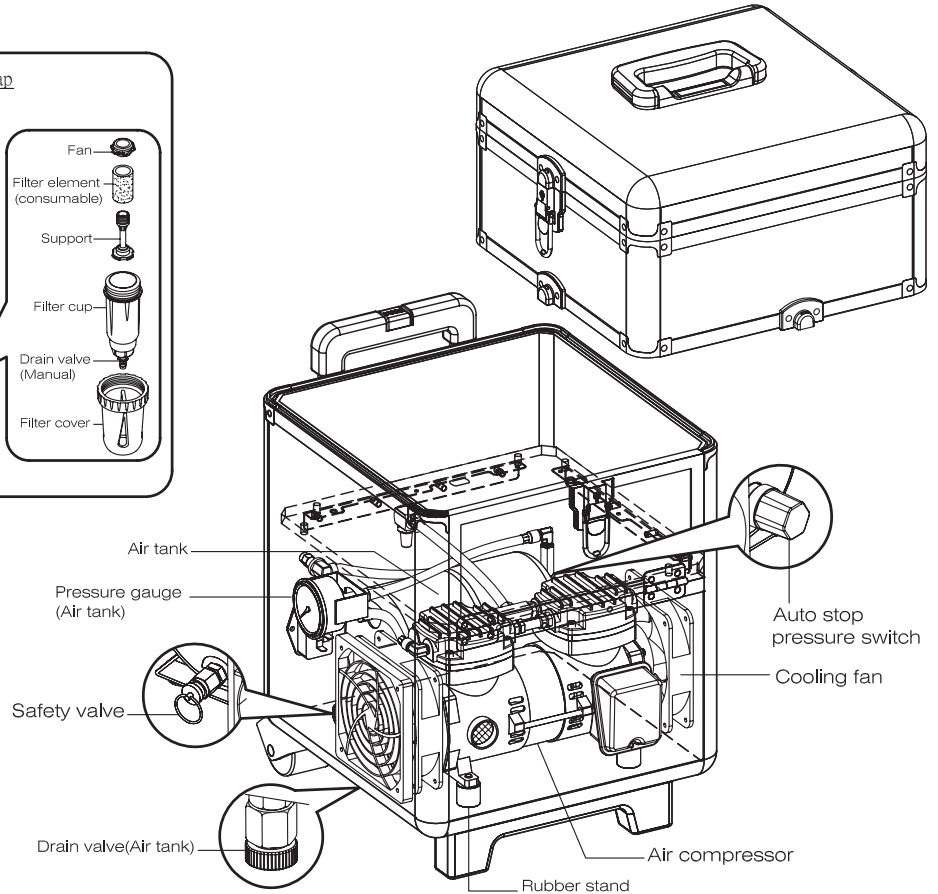
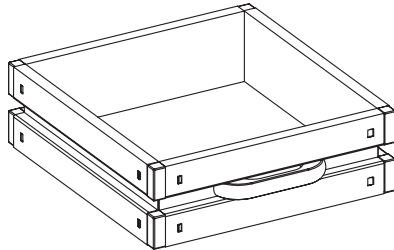
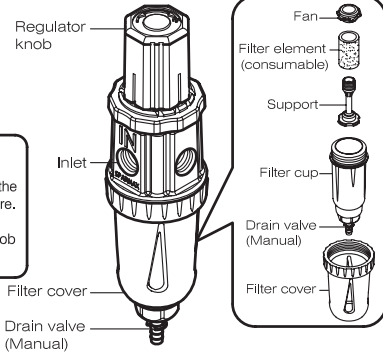

# EXPLODED DIAGRAM (CONT'D)

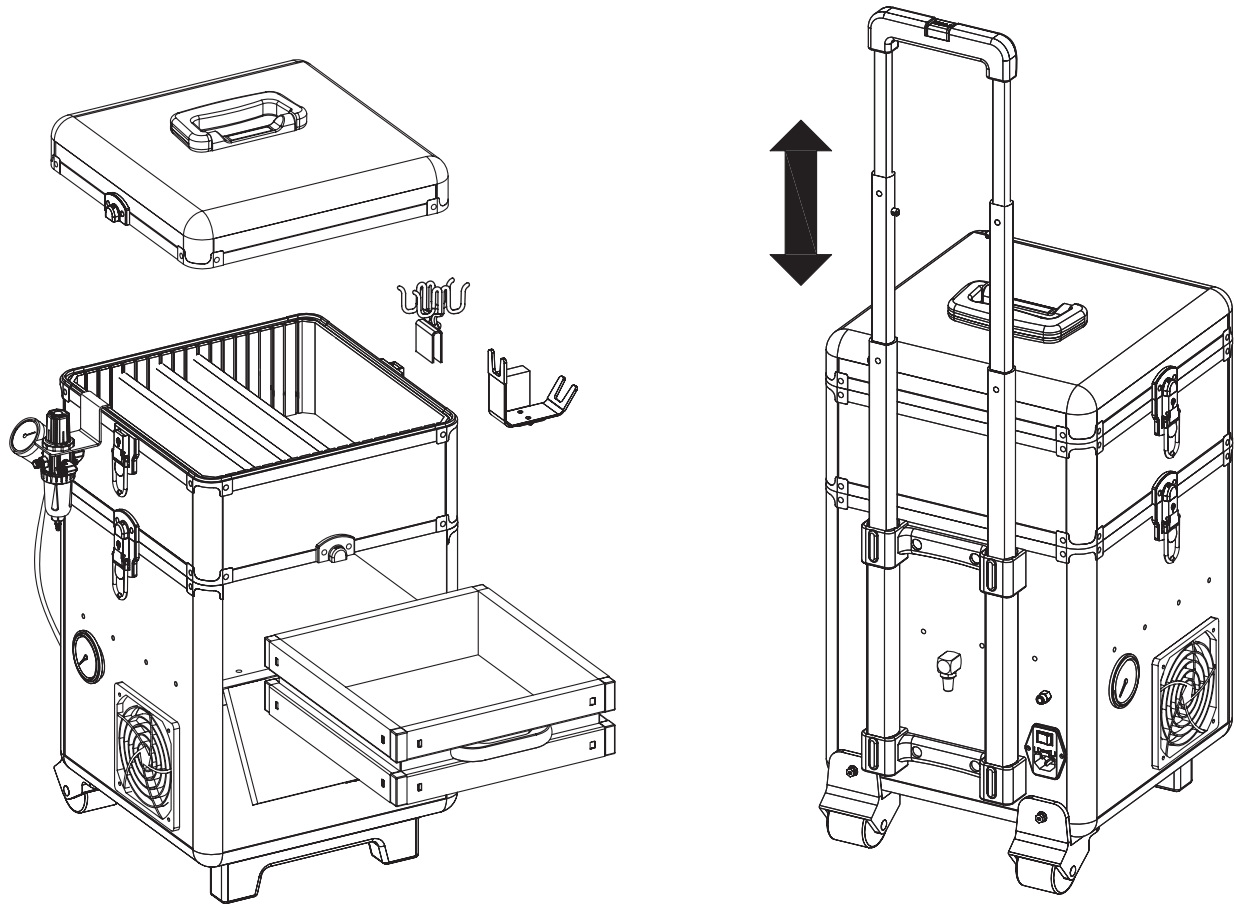

## GETTING STARTED

### **Unpack the compressor and all packaged components. Enclosed you will find:**

- Maxx Jet Compressor
- Black vinyl connector air hose (compressor to regulator)
- One (1) airbrush hose (regulator to airbrush)
- One (1) air hose (regulator to spray gun)
- One (1) airbrush holder
- One (1) spray gun holder
- One (1) dual manifold air regulator and gauge
- One (1) power cord

### **Set Up**

1. Remove top lid off compressor exposing top accessory tray.
2. Attach the power cord to the unit near the base of the retractable handle.
3. Screw one end of the black vinyl connector air hose onto the air outlet above the on/off switch.
4. Screw the other end of the black vinyl connector air hose onto the air regulator input.
5. Mount the air regulator on the edge of accessory compartment by sliding it onto the edge. Do the same with the airbrush holder and spray gun holder.
6. Take the airbrush hose (air hose with small fitting on one end and large fitting on the other) and screw the large fitting onto the air regulator output. (There are 2 outputs. Choose one.)
7. To use the optional second output, remove the protective cap from the second output of the air regulator.
8. Take the spray gun hose (large fittings on both ends) and screw one end to the second output on the air regulator.
9. Now you can screw your Iwata airbrush onto the airbrush hose and your Iwata G-Series or RG-3 onto the spray gun hose.



## GETTING STARTED (CONT'D)

10. Place your airbrush on the airbrush holder and your spray gun onto the spray gun holder.
11. Plug the compressor into a grounded wall outlet. (Avoid using an extension cord.)
12. Turn the compressor ON by pressing down the on/off switch back of the unit. (You will see the button light up.)
  - A. The Maxx Jet will run until its storage tank fills up, then stop. As you run your airbrush, the stored air will deplete. At a certain point the Maxx Jet will turn itself on to replenish the stored air.

### Using The Compressor

1. Turn compressor on by pressing the power button.
  - \* You will see the button light up. If there is no air in the air tank then the compressor engine will turn on and fill up the tank.
2. To adjust the air pressure, pull up on the black knob to unlock it.
  - A. Twist clockwise to raise the pressure.
  - B. Twist counter-clockwise to lower the pressure.

**Note: There's a + and - sign on top of the knob with arrows to remind you which direction raises and lowers pressure.**
3. After you've obtained the desired pressure, push down on the knob to lock it in place.
4. While using the compressor, you'll notice moisture start to condense in the clear plastic bowl of the moisture trap on the air regulator.
5. When droplets start to form in the trap, simply press up on the pressure release valve underneath the clear plastic bowl to release the built up moisture. **Note: How often you need to do this will vary based on the weather and how much humidity is in the air.**
6. When the airbrush or spray gun is not in use it may be placed in the appropriate holder.

## ENDING A SESSION

1. Release any built up moisture in moisture filter.
2. Turn off the compressor.
3. Release any leftover air by pressing down on your airbrush trigger (being careful of any excess paint) or unscrewing your airbrush from the airhose.
4. The air storage tank will collect moisture and will need to be drained. How often is based on how much humidity is in the air. (Drain the tank after every use for optimal lifespan.)

## MAINTENANCE

### **DRAINING MOISTURE FROM THE AIR STORAGE TANK**

1. Turn off the compressor.
2. Depressurize the tank by releasing the remaining air in the tank. Air can be released through the airbrush or through the moisture drain valve.
3. Unscrew the nut from the air tank drain valve located on the back of the air storage tank.
4. Tip the compressor back and let it drain.
5. When it is finished draining, set compressor upright.
6. Screw the nut back into the air tank drain valve.

### **REMOVE THE EXTERNAL AIR INTAKE FILTER**

- Use a crescent wrench (or 16 mm wrench) adjusted to fit the flat faces of the external air filter mounted to the back of the case.
- With the wrench fitted to air filter unscrew the external air filter by turning the wrench counter-clockwise until it is unthreaded from the case.
- If the material clogging the filter is water soluble, (ie., tanning liquid, cosmetics, water colors) soak the air intake filter in warm and soapy water. Rinse by running through the threaded end of the filter and let air dry.
- If the material clogging the filter is solvent-based, soak the air intake filter in appropriate solvent bath. Use forced air from your airbrush, through the threaded end to push solvent and residue out from the filter.
- Test the filter by blowing into the back, threaded end, and if air flows through it freely then the filter is clean. If not repeat cleaning cycle or replace filter.
- Gently thread the clean external air filter into place and tighten with a wrench until snug. Be careful not to over tighten as this may strip the threads.

## MAINTENANCE (CONT'D)

### **CLEANING THE VENT FILTERS**

- Since this filter generally attracts dust and dirt, use a small hose from a vacuum and run the end of the vacuum over the filter while it is in place.
- If it requires advanced cleaning, remove the plastic vent cover by using the flat end of a screwdriver placing it underneath the outside edge and gently pry it off.
- Remove the vent filter, it is only held in place by the vent cover.
- Wash gently in warm and soapy water. Rinse and allow to dry.
- Re-fit the vent filter into place and replace vent cover.
- If the vent filter is not cleanable replace with new vent filter.

### **RELEASING BUILT-UP MOISTURE IN THE MOISTURE FILTER**

- Release moisture by pushing up on the moisture drain valve located underneath the moisture filter with a paper towel.
- For optimal performance, do not allow excess water build-up in the moisture filter.

*DO NOT use oil in/on the compressor.*

## MAINTENANCE (CONT'D)

### CHANGING THE AIR INTAKE FILTER

- If the external air intake filter is clogged with debris and cannot be cleaned it will need to be replaced.
- Use a crescent wrench (or 16 mm wrench) adjusted to fit the flat faces of the external air filter mounted to the back of the case.
- With the wrench fitted to air filter unscrew the external air filter by turning the wrench counter-clockwise until it is unthreaded from the case.
- A replacement external air filter is included with the Maxx Jet. Extras can be purchased separately.
- Gently thread new external air filter into place and tighten with a wrench until snug. Be careful not to over tighten as this may strip the threads.

### CHANGING THE FAN FILTER

- If the external air intake filter is clogged with debris and cannot be cleaned it will need to be replaced.
- Remove the plastic vent cover by using the flat end of a screwdriver placing it underneath the outside edge and gently pry it off.
- Remove the fan filter, it is only held in place by the fan cover.
- Two replacement fan filters are included with the Maxx Jet. Extras can be purchased separately.
- Replace with clean fan filter.
- Replace fan cover by snapping it into place.

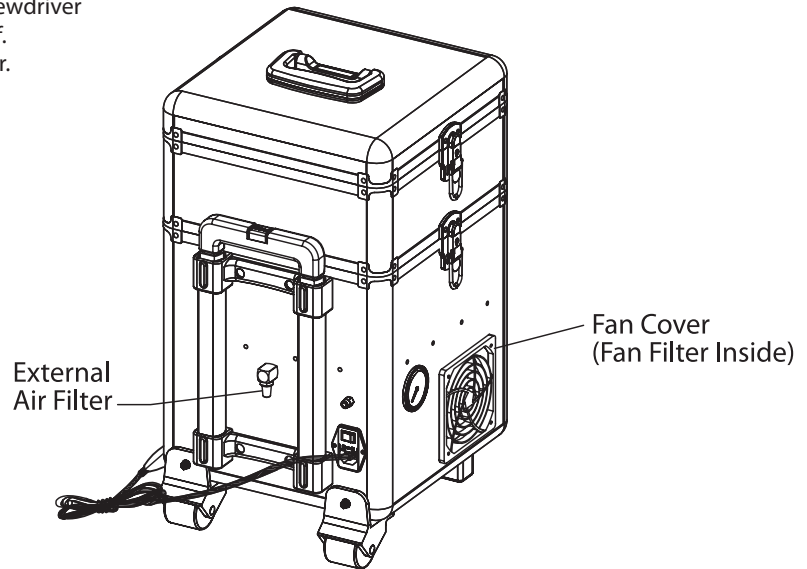

## TROUBLESHOOTING

### COMPRESSOR TURNS ON AND OFF WHILE AIRBRUSH IS NOT SPRAYING AIR

The compressor has an air leak. When this happens:

1. Spray all connections with a soapy water solution. Resulting bubbles indicate an air leak.
2. Tighten connections.
3. If bubbling doesn't stop, try wrapping threads with thread sealant tape (max 3 wraps only) or applying beeswax to the threads. Both methods provide an airtight seal.
4. If the air leak is in the middle of an airhose the hose will need to be replaced.

### FOR ANY OTHER PROBLEMS OR ISSUES

Contact ANEST IWATA-MEDEA at 503-253-7308 or email at: [info@iwata-medea.com](mailto:info@iwata-medea.com)

## WARRANTY

All Iwata compressors are *Warranted* against all manufacturing defects of material and manufacture or workmanship for a period of ONE year from the date of purchase\*. This warranty does not cover intake air filters as periodic replacement of these parts is REQUIRED due to normal wear. Any part or material that is or becomes defective so as not to be usable within this period will be repaired or replaced. This warranty does not cover damage caused by negligence or a compressor that has been altered or abused in any way.

Call or email Anest Iwata-Medea before returning a compressor for the appropriate procedure for warranty repairs. Any material that is shipped to Anest Iwata-Medea without prior authorization will not be accepted.

- Anest Iwata-Medea offers technical support over the phone at no charge. **Call Customer Care at 503-253-7308 Monday – Friday, 8am – 4:30pm Pacific Time.** Telephone support includes general usage information, cleaning tips, and troubleshooting.
- **NOTE:** All compressors returned for repair must have a Return Authorization Number. **Please call 503-253-7308 to obtain an RA number**, instructions and shipping address.

Warranty service will be provided only at authorized Anest Iwata-Medea service centers. You must pay all charges for shipping/ transporting your Iwata compressor to/from these service facilities.

*Anest Iwata-Medea, Inc. will not be responsible for damage to persons or property, commercial loss or any other incidental or consequential damage caused by a defective compressor. However, some states do not allow the exclusion or limitation of incidental or consequential damages, so the above limitations may not apply to you.*

*All implied warranties, including any warranty of merchantability or fitness are limited to the duration of this written warranty. However, some states do not allow limitations on how long an implied warranty lasts, so the above limitation may not apply to you.*

*\* Please keep the sales receipt.*

*Genuine Iwata*



**iwata**

by ANEST IWATA

**www.IWATA-AIRBRUSH.com**